



## ELICA'S EXCLUSIVE PLUS FEATURES

Introducing Volta, a line of powerful cooktops equipped with top-end induction technology, ensuring precise and efficient cooking like never before.

The modern design showcases a luxurious black glass surface and electronic side touch controls, allowing to seamlessly blend style and functionality. Available in three convenient widths - 24", 30", and 36" - Volta offers a range of options to fit any kitchen space.

Additionally, our cooktops come with multiple plus features that will revolutionize your cooking experience.

- STOP & GO** - If you are interrupted while cooking, with just a single movement, pressing the Stop & Go button, you can switch off all the cooking zones and walk away with complete confidence and safety.
- DELAY SWITCH OFF** - A smart timer feature allows you to set the automatic switch-off of the product after a predetermined time. Delayed shutdown may be used in order to leave the hood on even after cooking, so to fully remove stubborn odors and residual humidity.
- TIMER** - Set the cooking time and start the countdown. At the end the cooking area will be automatically switched off and a beep will sound. You can set independent timers on more than one area at the same time.
- TEMPERATURE MANAGER** - The cooktop can be used with three different standard programs (100°, 160° or 200° degrees F) to always ensure a perfect cooking.
- POT DETECTOR** - The hob automatically detects the presence of the pot on the cooking area provides heat only when it is correctly positioned.
- TOUCH CONTROLS** - Multifunction electronic touch control behind sleek black glass and illuminate red when activated.
- CHILD LOCK** - This avoid that the cooking or extraction areas are not accidentally switched on. The function can be enabled when the product is switched on but the cooking areas and extraction are switched off.
- TOTAL INTEGRATION** - The Total Integration products have been design to be seamlessly integrated into the kitchen whilst maintaining harmony with the surroundings.
- WARMING MODE** - Designed for a low temperature cooking, ideal for heating liquids without worrying about the over-heating. Keeps prepared food warm, while other foods are still cooking.
- BRIDGE ZONES** - Avoid heat to be progressively dispersed when using longer or larger pans, by joining two cooking areas into one single larger area. With the same power, uniform and constant temperature.
- EASY MAINTENANCE** - All the components, such as the grease and odour filters, can be easily accessed and removed so they can be washed or rapidly replaced. Making it a low-maintenance product.
- EXTRA LARGE ZONE** - Cooking using large pots & pans (up to 12" diameter), or prepare special dish faster, thanks to highpower levels, in comparison to the average induction hob on the market.

PRELIMINAR SPECSHEET

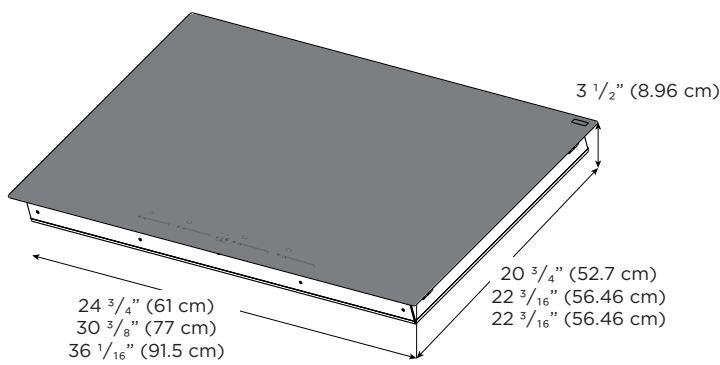

# VOLTA

## SPECIFICATIONS



Width:	24" UNIT	30" UNIT	36" UNIT
Model:	EIV424BL	EIV430BL	EIV436BL
Dimensions:	24" W x 20 3/4" D x 3 5/8" H	30" W x 20 3/4" D x 3 5/8" H	36" W x 20 3/4" D x 3 5/8" H
Cooking Zones:	4 Cooking Zones	4 Cooking Zones	5 Cooking Zones
□ Burner 1 □ Burner 2 □ Burner 3 □ Burner 4 □ Burner 5	BRIDGE 3kW   7 1/2" x 8 1/4" 3kW   7 1/2" x 8 1/4" 1.8kW   Ø 5 3/4" 3kW   7 1/2" x 8 1/4"	3.7 kW   7 1/4" x 8 5/8" 3.7 kW   7 1/4" x 8 5/8" 2.2 kW   Ø 5 3/4" 3.7 kW   Ø 10 1/4"	3.7 kW   7 1/4" x 8 5/8" 3.7 kW   7 1/4" x 8 5/8" 2.2 kW   Ø 5 3/4" 3.7 kW   Ø 8 1/4" 3.7 kW   Ø 10 1/4"
Control:	Slider Touch Control		
Heating Type:	Induction		
Heating Level:	9 Levels + Booster *(see details in chart below)		
Installation Type:	Built-In / Self Rimming or Flush		
Electrical:	208 - 240 V - 60 Hz		
WARRANTY:***	Three (3) Years Parts & In-Home Labor. Earn an additional TWO (2) Year of Parts & In-Home Labor by registering on elica.com.		

VOLTA 24"



VOLTA 30"



VOLTA 36"



Cooking Level	Power (W)**
Low	53 W
Level 1	63 W
Level 2	105 W
Level 3	168 W
Level 4	252 W
Level 5	378 W
Level 6	588 W
Level 7	882 W
Level 8	1344 W
Level 9	2100 W
Booster	3700 W

### Glass Specifications

Material	Glass-ceramic cooking panel
Appearance	Deep - black color
Thickness	4mm
Color in reflexion	Black
Color in transmission	Amber
Surface structure	Though crystal smooth scratch and stain-resistant

\*\*Values reference to the maximum power 3.7 kW burner

\*The product images shown are for illustration purposes and may not be an exact representation of the product.

PRELIMINAR SPECSHEET

# VOLTA

## CUT OUT DIMENSIONS

### SELF RIMMING INSTALLATION

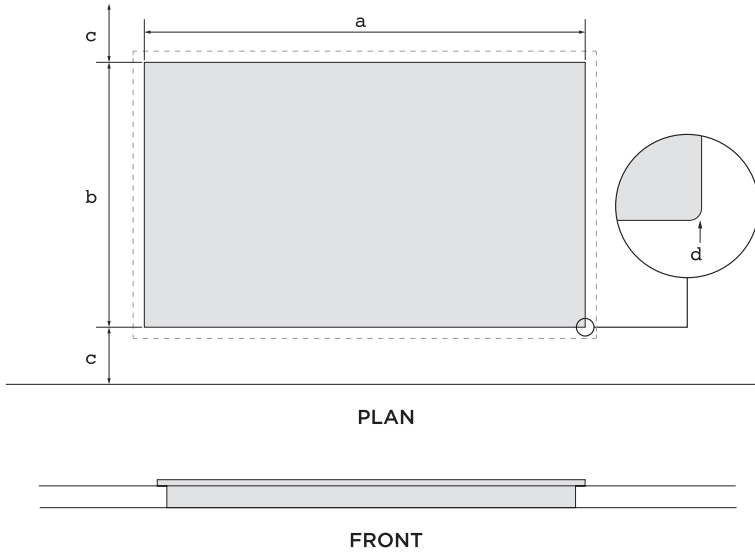

	Model	Model	Model
	<b>EIV424BL</b>	<b>EIV430BL</b>	<b>EIV536BL</b>
<b>a</b>	23 <sup>1</sup> / <sub>8</sub> " (58.7 cm)	28 <sup>7</sup> / <sub>8</sub> " (73.34 cm)	34 <sup>9</sup> / <sub>16</sub> " (87.79 cm)
<b>b</b>	21" (53.3 cm)	22 <sup>1</sup> / <sub>2</sub> " (57.06 cm)	
<b>c</b>	1 <sup>5</sup> / <sub>16</sub> " (5 cm) minimum		

### FLUSH MOUNTED INSTALLATION

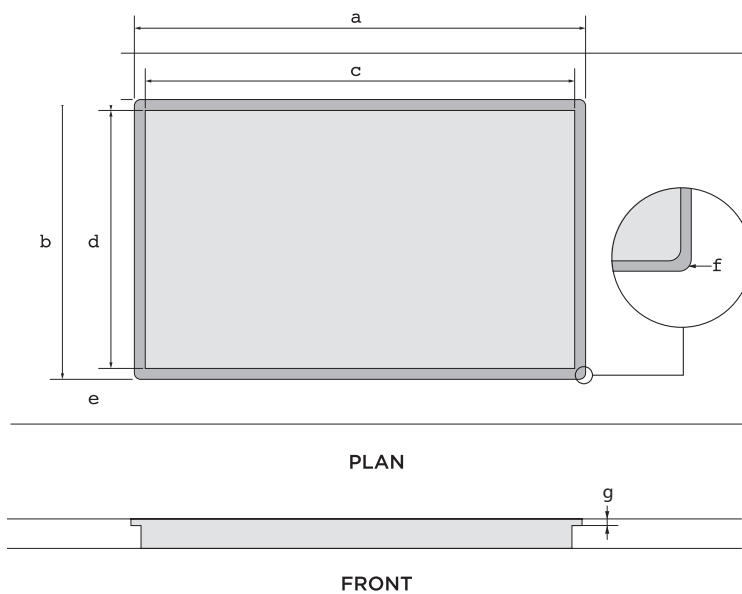

	Model	Model	Model
	<b>EIV424BL</b>	<b>EIV430BL</b>	<b>EIV536BL</b>
<b>a</b>	24 <sup>1</sup> / <sub>4</sub> " (61.6 cm)	30 <sup>9</sup> / <sub>16</sub> " (77.65 cm)	36 <sup>1</sup> / <sub>4</sub> " (92.1 cm)
<b>b</b>	21" (53.3 cm)	22 <sup>1</sup> / <sub>2</sub> " (57.06 cm)	
<b>c</b>	23 <sup>1</sup> / <sub>8</sub> " (58.7 cm)	28 <sup>7</sup> / <sub>8</sub> " (73.34 cm)	34 <sup>9</sup> / <sub>16</sub> " (87.79 cm)
<b>d</b>	19 1/2" (49.5 cm)	20 1/8" (52.07 cm)	
<b>e</b>	1 <sup>5</sup> / <sub>16</sub> " (5 cm) minimum		
<b>f</b>	4 x Ø 7		
<b>g</b>	1/4" (0.65 cm)		

PRELIMINAR SPECSHEET