

ICONIC SERIES  
**GLIDE**



ELICA'S EXCLUSIVE PLUS FEATURES

The ultra-thin 23/4" Glide brings a sleek understated look to modern kitchens that desire minimalism. The crescent shape profile is uncommon and attractive, while the retractable, curved glass visor helps capture cooking vapors, and empowers the user to operate the blower and lights without reaching for the controls. Glide comes equipped with a 400 CFM blower, plus reliable electronic push button controls operate 2 LED lights and the 4-speed blower. Easy maintenance and a cleaner kitchen are ensured by a dishwasher safe, stainless steel mesh filter.

Glide is designed for standard ducted installations, but can also be installed as a recirculating system.

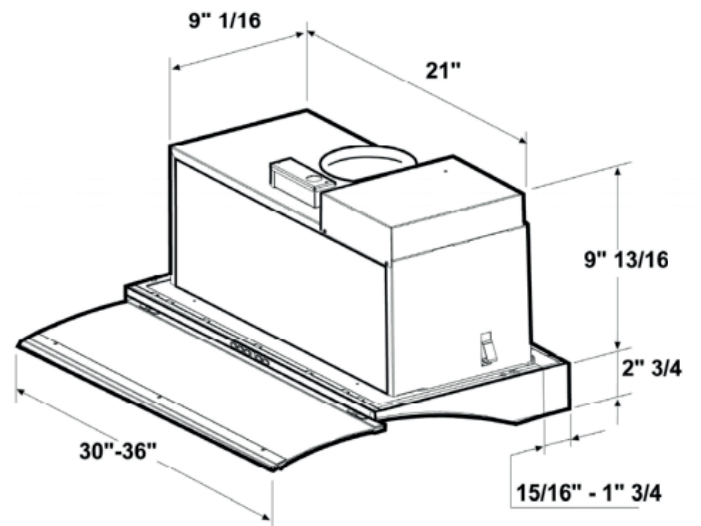

MOUNTING  
HEIGHT  
RANGE

## SPECIFICATIONS

Width:	30" UNIT	36" UNIT
Model:	EGL430S1	EGL436S1
Dimensions:	30"W x 11 1/2" - 19 3/4"D x 12 4/7 "H	36"W x 11 1/2" - 19 3/4"D x 12 4/7 "H
Blower Type (internal):**	400 CFM (3 speed + boost)	
Noise (sones):**	5.9 Sones	
Finish:	Stainless Steel + Clear Glass	
Controls:	Electronic Push Button	
Illumination:	2 LED 3 W 3000 K	
Filter Type:	1 Dishwasher-Safe, Stainless Steel Microhole filter	
Duct Transition:	6" Round top and rear	
Installation type:	Ducted or Recirculating (Kit sold separately)	
Electrical:	120V-60Hz, 270 W	
KITS:		
Recirculating Kit:	F00539 (contains 1 carbon filter, clips and cabinet grate)	
CFM Reduction Kit:	KIT02748 (achieves < 300 CFM)	
WARRANTY:***	Two (2) Years Parts & In-Home Labor. Earn an additional One (1) Year of Parts & In-Home Labor by registering on elica.com.	

## PLUS FEATURES



LED LIGHT - LED lighting is undoubtedly the smartest solution in terms of energy saving. Expected life is over 20,000 hours, and should last the full life of the hood.



CLEAN FILTER ALARM - When activated, your hood will emit a "beep" signal to let you know when is time to clean your filters. For some models, an intermittent light will remain active until cleaning filter action is completed. See instructions manual to activate feature.



REPLACE FILTER ALARM- When activated, your hood will emit a "beep" signal let you know when is time to replace the carbon filters. See instructions manual to activate feature.

HVI Certified Ratings	High Speed	Working Speed	Duct Size
CFM	230	160	6" (Vertical)
Sones	4	1.5	6" (Vertical)

\* The product images shown are for illustration purposes only and may not be an exact representation of the product.

\*\* Blower performance indicates the performance of the blower by itself. Performance claims are not HVI certified but were established in accordance with HVI Standardized test procedure. For Certified Ratings, please refer to HVI Certified Product Directory. Electric Ratings are declared according to UL.

\*\*\* For valid warranty extension, register within 3 months from purchase. For USA & Canada Users Only.